

ALL-ROUND HOT WATER BUTLER

SUNSOL
SOLAR WATER HEATER



Infinitely sunshine, borderlessly sharing



Introduction

Quality assurance and customer satisfaction lead SUNSOL's top belief. SUNSOL is one of the most professional manufacturers producing energy conservation and environment-friendly products, such as solar water heater, solar panel, wind turbine etc. Through past several years' development, SUNSOL Solar has been the outstanding one in the solar energy industry.

We have precious experiences in exporting our products to the Southeast Asian, Australian, European and the American markets. Our products are well-known greatly due to high quality and reasonable price. To present our customers more considerate service, SUNSOL has modernized our production equipment, enhanced production technology and management mode. To form designing, producing, quality checking, selling as an organic whole, from quality control of the input of the raw materials and feedback of the after-sale service, we have introduced TQM and other advanced producing methods to ensure the interest of our customers.

The 21st century is the era of the knowledge economy, full of the fierce competitions of technology and managing mode, but meanwhile, we can tell that there are also so many opportunities to get mutual benefits. Welcome domestic and international friends to cooperate cordially with SUNSOL Solar. We believe with our best efforts, we can create the prosperity and development for both of our business.

Tri-element Vacuum Tube

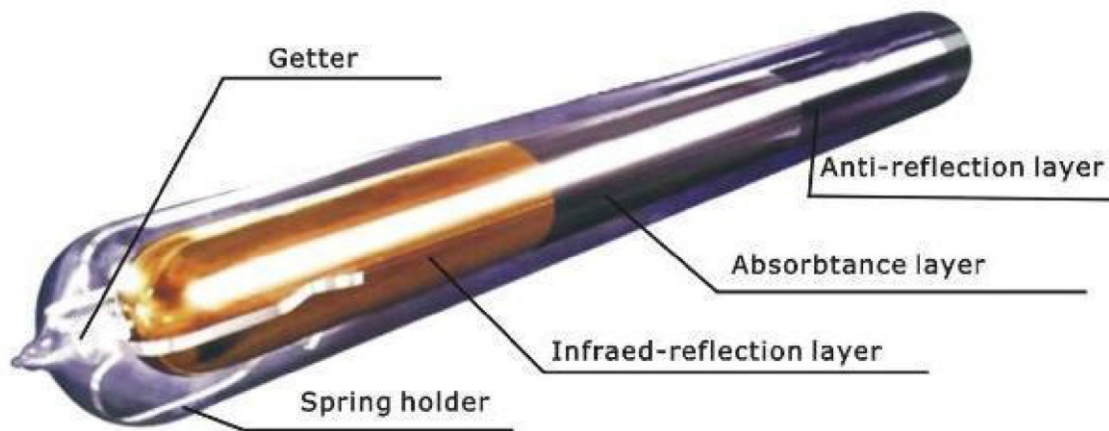

Features:

Vacuum Tube technology:

Models 47mm 1500mm 58mm 1800mm

Weight 1.35kg 2.29kg

Structure All-glass-coaxial All-glass-coaxial

Double-layer tubes double-layer tubes

Outer tube diameter 47mm 58mm

Inner tube diameter 37mm 47mm

Outer Tube thickness 1.6mm 1.8mm

Inner tube thickness 1.6mm 1.8mm

Material of coating Al N/Al N-SS/Cu Al N/Al N-SS/Cu

Absorptance 0.94~0.96 0.94~0.96

Emittance 0.04~0.06 0.04~0.06

Vacuum $P \leq 5 \times 10^{-3} \text{pa}$ $P \leq 5 \times 10^{-3} \text{pa}$

Stagnation temperature 270~300 270~300

(height)

Heat-loss coefficient $\leq 0.6 \text{w/ m}^2$ $\leq 0.6 \text{w/ m}^2$)

Bearing hailstone ability 25mm 25mm

Pressure-endure ability 1MPa 1MPa



Heat Pipe Vacuum Tube

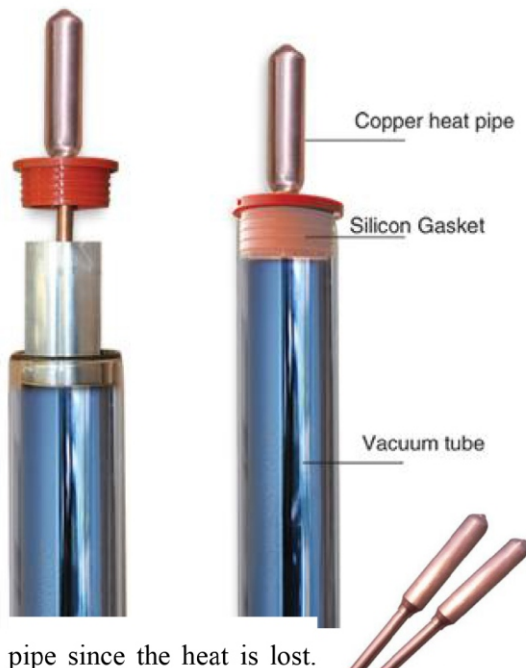

pipe since the heat is lost.
solar energy is transferred continuously.

As a key component of the heat-pipe collector, heat-pipe plays a very important role in this solar collecting system. The heat-pipe is composed of heat-energy absorption unit and condenser unit, and is hollow with the space inside evacuated. Under the vacuum circumstance, the air pressure inside heat-pipe is very low, thus the medium can be evaporated easily when absorbing certain energy. This vapour rapidly rises to the condenser zone and transfers heat, then becomes the liquid and returns to the bottom of the heat pipe. This process repeats again and again, so the

Working Principle

On Sdasun heat-pipe collector, the condenser zone of the heat-pipe is inserted to the copper sleeves which are distributed on the water pipe averagely. After the solar energy is absorbed by the vacuum tubes, it is transferred to the heat-pipe through the aluminum fin. Heated by the energy, the medium in the heat-pipe is working and transferring the heat energy to the condenser zone. When water or other medium in the water pipe flows across the copper sleeves, they would bring the energy and be heated.

The heated water or other medium makes water in the tank hotter and hotter by walking across the coils in the tank.

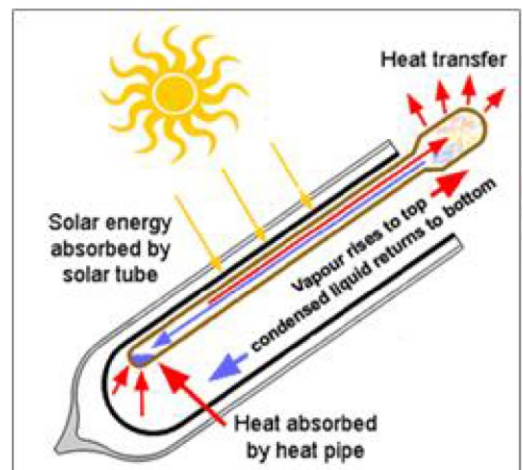

Solar Thermal Collector

How does a solar collector work

- ❖ Vacuum tubes absorb sunshine from the sun
- ❖ Vacuum tube transfers heat energy to heat pipe
- ❖ Fluid goes through copper, and then be warmed by the heat pipe which connected with copper.
- ❖ The glass wool insulation prevent heat loss.

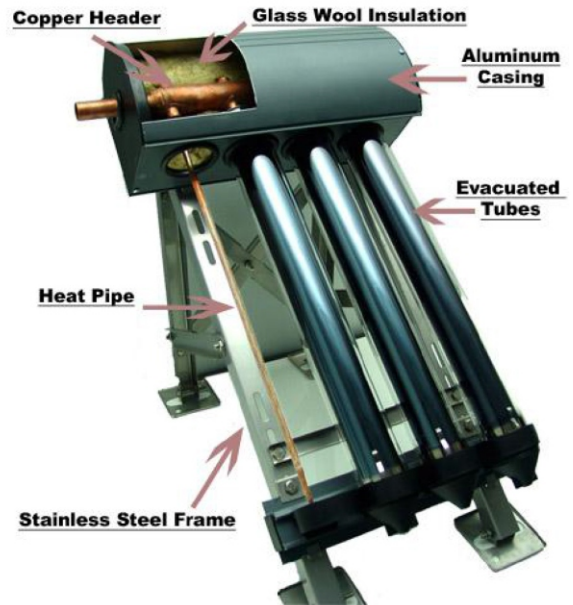
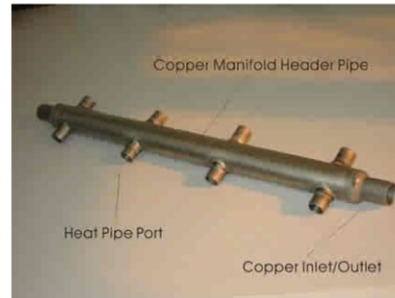

Features

- ❖ Pressurized operation and no water flow in the vacuum tube, so water scale and tube exposition are avoided.
- ❖ It can be integrated with the architecture perfectly and be connected with the existing pipes.
- ❖ Interferential film coated vacuum tube with absorptance among 94% to 96%, and vacuum degree of 5×10^{-4} pa; its service life will be not

less than 15 years.

- ❖ Heat pipe collectors have passed the the Solar Keymark certificate and CE certificate, met EN12975 standard.



Specification

- ❖ Manifold (interior): Red copper
- ❖ Manifold (exterior): Aluminum alloy
- ❖ Glass tube dimensions: 58mm x 1.8m / 47mm x 1.5m

- ❖ Tube no: 10/12/15/18/20/22/24/25/28/30tube
- ❖ Heat preservation: 72 hrs
- ❖ Hail resistance: 25mm
- ❖ Max pressure: 6 bar
- ❖ Coating of vacuum tube: ss-c/cu
- ❖ Heat pipe: Anti-freezing > -35 degree

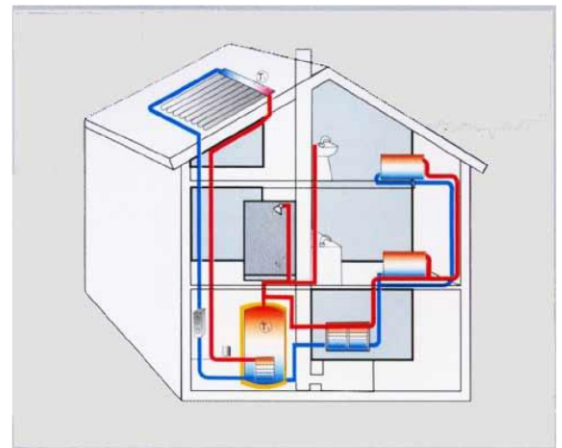

Seperated Pressurized Solar Water Heater

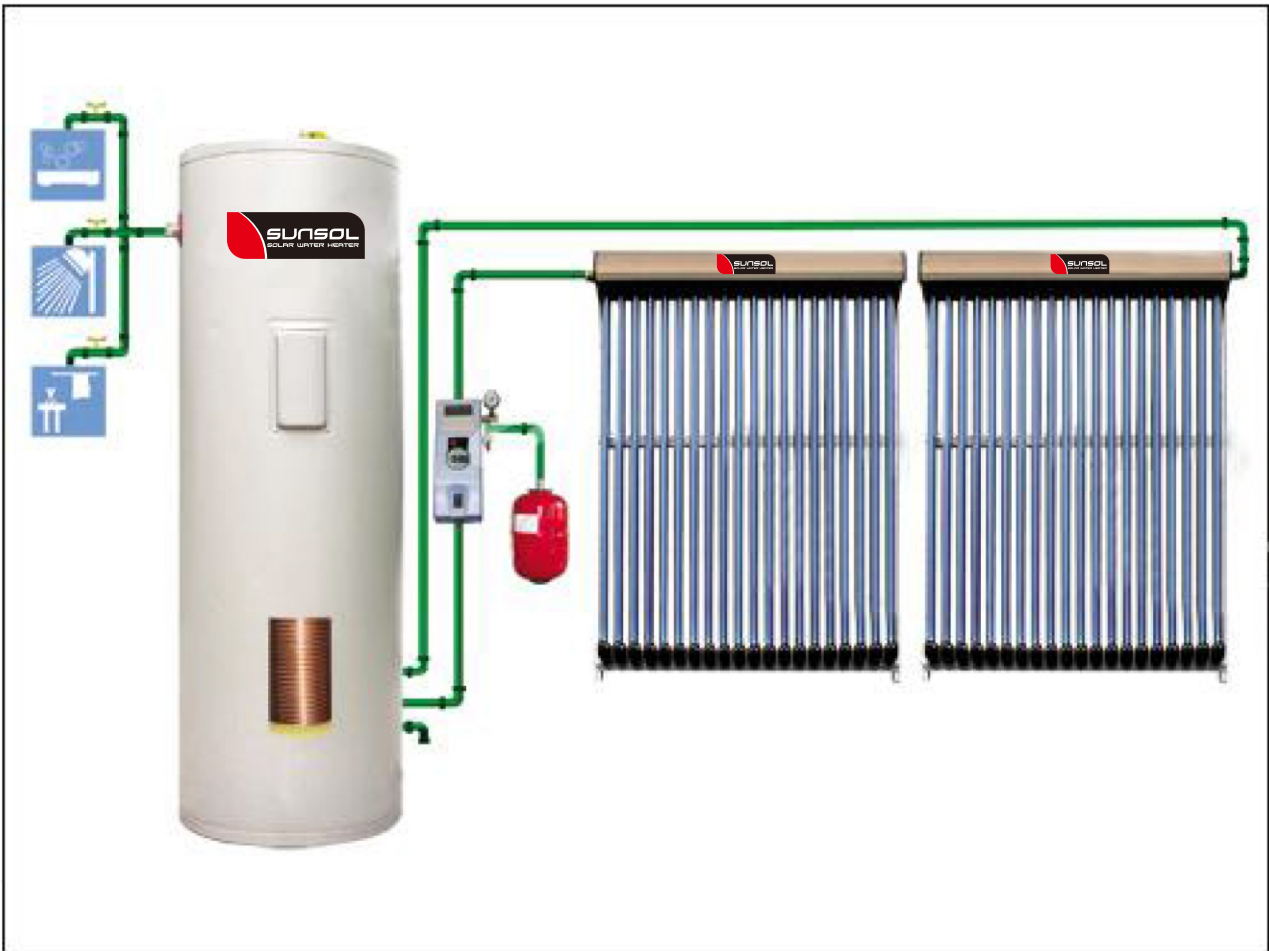

Feature

- 1.The upright tank can make the water temperature to a high level. It can hot the water instantly.
- 2.The tank inside the building, the hot water loses less energy than the normal one.
- 3.The heater collector and the water tank is separated, that makes the system combine with the building perfectly, which will reduce the sightseeing for the building and environment around.
- 4.Back up with electric heater so that in the day without sunshine hot water can also be used.
- 5.Can be combined with gas or electric



heater.

6.Max. Pressure: 12bar; Operating Pressure: 6 bar.

7.It can be used for other function, such as waring.

Specification

1.Inner tank: SUS304 2B food grade stainless steel.

2.Outer tank: white color steel or Stainless steel.

3.Insulation: 55--60mm imported PU.

4.Copper coil: 15m each, diameter 12mm,thickness 1mm.

5.Heatpipe: Ati-freeze:-35C

6.Capacity:100L,150L,200L,250L,300L,400L,500L

Working Station

1. Operating screen

2. Manometer

3. Pump speed adjust switches

4. Temperature difference circulation pump

5. Flow rate indicator

6. Return circuit connector

7. Safety valve

8. Expansion vessel connector

9. Return circuit connector

10. Wall mounting

11.Expansion vessel:5L,8L,12L,19L,20L,24L,10 bar pressure



Working principle

The collector absorbs solar energy and transmits it to the water tank through circulation. When the temperature of the collector reaches the set value, the controller starts the circulation pump automatically. The circulation pump makes heat-conducting liquid circulate automatically.



Non-pressurized Solar Water Heater



Feature

1. Cheap and reliable solution, Simple structure, Easy installation
2. High efficiency
3. Withstands water pressure no more than 0.1MPa
4. Operated without any power supplying
5. Electric heater can be used 1500W or 3000W
6. Hot water can be used directly, or can be used as a pre-heat



Specification

1. Material of inner water tank: 0.31mm, 0.4mm, 0.5mm / 0.6mm, 304-2B (food-level stainless steel)
2. Material of outer water tank: stainless steel / color steel / fluorin carbon 0.31mm, 0.4mm, 0.5mm
3. Heat preservation: 55mm imported PU
4. Vacuum tube: single target vacuum tube, coating: AL/N/AL
5. Bracket: stainless steel, thickness 1.2mm / 1.5mm
6. Angle of bracket: 25°, 38°, 45°
7. Reflector: stainless steel sheet or strip
8. Daily efficiency: >50%
9. Optional electrical heater: 1.5kw/2kw



Non-pressurized Flat Type Solar Water Heater



Technical specifications

1. Specification: 2m*1m*70mm/80mm/90mm;
2m*1.5m*70mm/60mm/90mm
2. Material of core: Copper and aluminum unfied core, heat pipe diameter: 22mm/25mm. Few welding line, high intension, and strong pressure resistance.
3. Coating: anode oxidation film
4. Tempered glass: High transmittance, good heat preservation, firm and long service life, thickness is 4mm or 5mm.
5. Work pressure: 0 Mpa
6. Aluminum alloy profile: electrophoresis aluminum alloy profile treatment, beautiful outlook and more high anticorrosion.
7. Special preservation: glass wool/ high dense polyurethane foam
Less heat loss, more efficiency and more beautiful



Integrated Pressurized Solar Water Heater

Feature

1. The copper pipe inside the vacuum tube could quickly transfer the heat into the water tank through heat conduction medium.
2. The system can endure the max pressure up to 0.6Mpa.
3. There is no water in the vacuum tube. It can endure the freezing -35 degree centigrade.
4. The vacuum tube can endure the 25mm hailstone.
5. Heat pipe has the functions of one-way heat transfer, small thermal capacity, low start-up temperature.
6. For inner tank, we adopt high frequent melting technology.
7. It can directly connect with tap water system.
8. It eliminates the low heat efficiency problem caused by fur.



Specification

1. Inner tank: SUS 304-2B food grade stainless steel 1.2mm--1.5mm;
2. Outer tank: SUS 304-BA stainless steel 0.31mm--0.41mm;
3. Bracket: Galvanized steel with powder painting 1.2mm--1.5mm;
4. Heat insulation layer: 55--60mm imported PU;
5. Vacuum tube: high borosilicate 3.3 ; coating: ALN/ALN-SSCU.

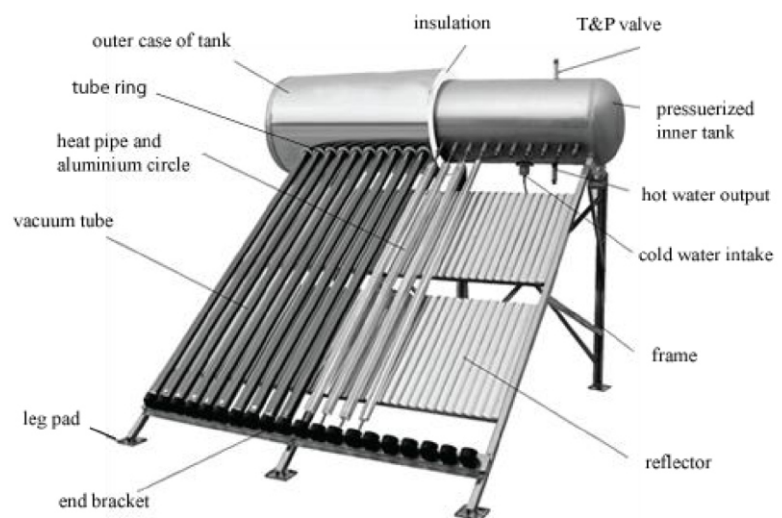

Working Principle

The pressurized water tank has no exhaust hole, therefore, it must bear the pressure came from tap water and hot water. When use, the hot water comes out because of water pressure. Vacuum tube absorbs solar energy, and conductive copper pipe transfers the heat into the pressurized water tank. In this case, the water inside the tank becomes hot. No water in the heat pipe makes the whole system could bear pressure.

Pre-heated Solar Water Heater



Component of Production:

1. Material of Inner Tank: SUS304-2B Stainless Steel, thickness: 0.4mm, 0.5mm, 0.6mm
2. Material of Outer Tank: Stainless steel, thickness: 0.31mm/0.4mm
3. Copper Coil: diameter : 12mm, thickness: 1mm
4. Heat Preservation : polyurethane foam with 55mm thickness
5. Magnetic-controlled Al-N-Al splash all glass evacuated heat-collecting tubes
6. Specification: $\Phi 58\text{mm} \times 1800\text{mm}$
7. Material of Support: Stainless steel ,thickness: 1.2mm/1.5mm
8. Capacity: 100L-300L

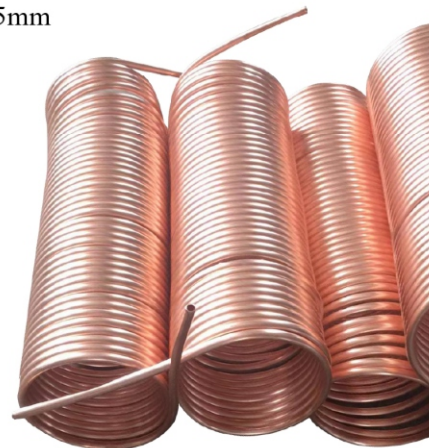

System Work Principle

1. The vacuum tube collector absorb the heat energy to heat the water in heat storage tank,
2. When using the hot water, the cold water flows through the inlet, the copper coil absorb the heat then transfer into the cold water ,so that the temperature rise up ceaseless,
3. For the original features of the copper coil, the water temperature of the outlet is close to the water temperature of the water tank ($\leq 3^{\circ}\text{C}$), so the high pressure of the cold water into the copper coil and absorb the temperature, at last the water can be used.



Solar Project solution

Feature



1. Central solar water heating system is designed based on customers' water consumption.

2. By collecting the solar heat, it can heat a great amount of water that can accommodate tens of and hundreds of people.

3. Added by the Fivestar's atmospheric hot water boiler and electric heating unit as an auxiliary part, the central solar water heating system can continuously supply hot water all the year around.

4. High efficiency, long operating life. Heat absorber applies high efficiency copper absorber of ultrasonic welding.

5. The stainless water tank is specially designed and characterized by storage and heat insulation in case of use day and night.

6. Fully automatically operated, energy and money saved. Central solar water heating system can work under automatic control.

7. In two or three years, the cost can come back due to the obvious economic benefit.

8. This system can be operated by remote controlling based on customer's requirements.



Specification:

1. Inner Tank: 0.4mm stainless steel (SUS304/2B)

2. Outer Tank 0.41-0.5mm Galvanized steel alloy/Stainless steel 0.4mm

3. Insulation layer: 40-50mm polyurethane

4. Vacuum tubes: 58*1800mm/47*1500mm

5. Remark: 50/60PCS vacuum tubes/set



Air Source Heat Pump Water Heater

Air source water heater making use of high efficiency environment protected refrigerating liquid, can generate hot water up to 60°C. The heat efficiency can be over 380%, saving more energy by 80% comparing with ordinary water heater, 30% comparing with pipe transmitting gas in city, 20% comparing with fuel water heater. There is no poisonous gas, liquid or trash letting while running

Air source water heater selection guide

When selecting an air source water heater, these conditions should be fully considered: local weather, daily average hot water demand, hot water sustainable demand time, average hot water demand per hour, hot water demand peak value, hot water temperature demand and supplement water temperature. Choose daily working time of the unit equally to 70% daytime, different water tank sizes to satisfy hot water demand peak value, defrosting matched unit or not (and type if needing) according to the local weather to meet hot water demand peak value

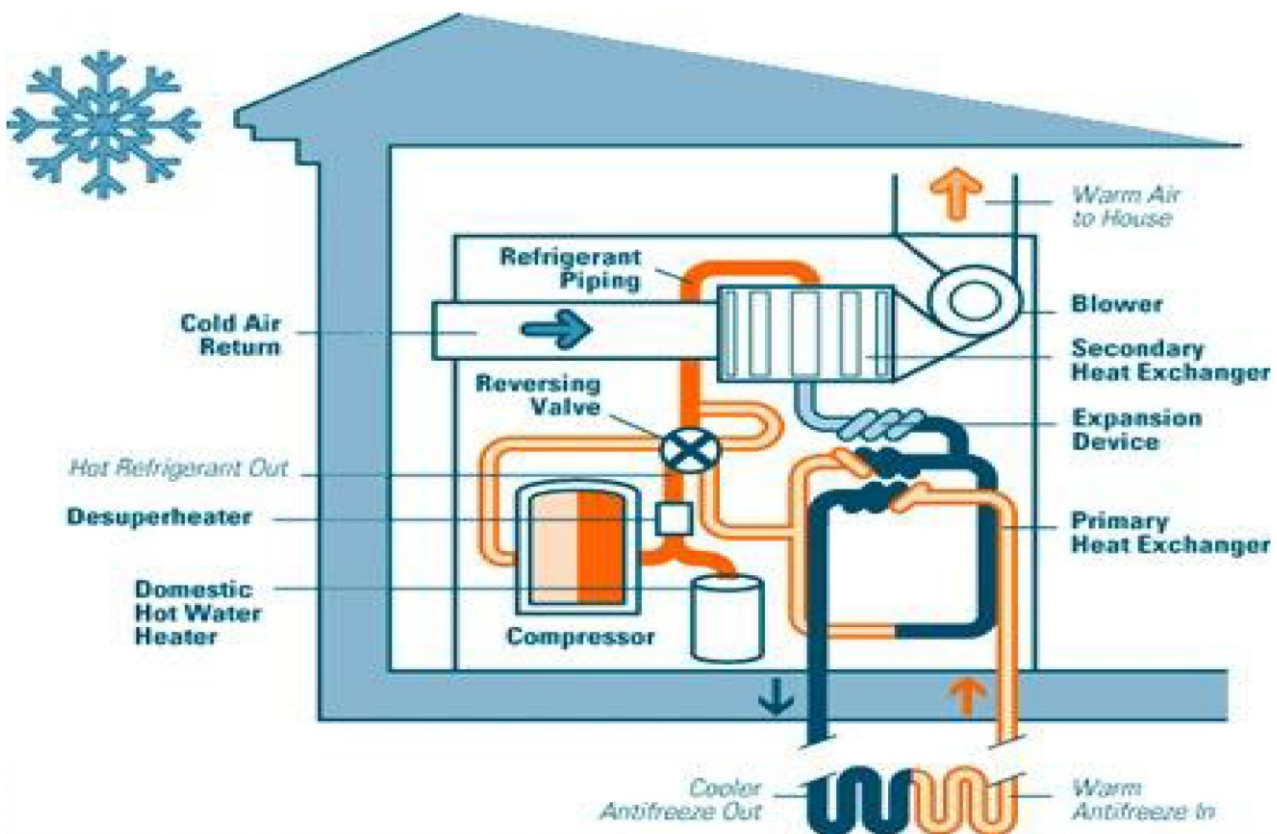

Specification

1. Water tank storage capacity: 100L, 150L, 250L, 320L, 400L, 500L, withstanding high pressure

2. Air compressor indoor unit: 9, 000BTU, 12, 000BTU, 18, 000BTU, 24, 000BTU, 36, 000BTU

3. Super insulated hot water tank, efficiently keep the water temperature stable

4. Intelligent control: Preserves heat, temperature controlled automatically



5. Easy installation, can work in basements, outer wall, garages etc

6. Works all day: Not affected by changes in the weather

7. Hot water output: 45-60 ° C

8. Energy saving: A) Heating efficiency: 350% b) Electric heater efficiency: 95%

9. Easy installation

10. Can work well to -15 ° C

Feature

1. Large pondage and supply

2. LASTING constant temperature

3. SAFETY

4. Intelligent control and Comfortable

5. Freeze-proof Function: In winter, will eliminate the frost automatically

6. Green environmental protection

7. Economical

8. Easy for setting

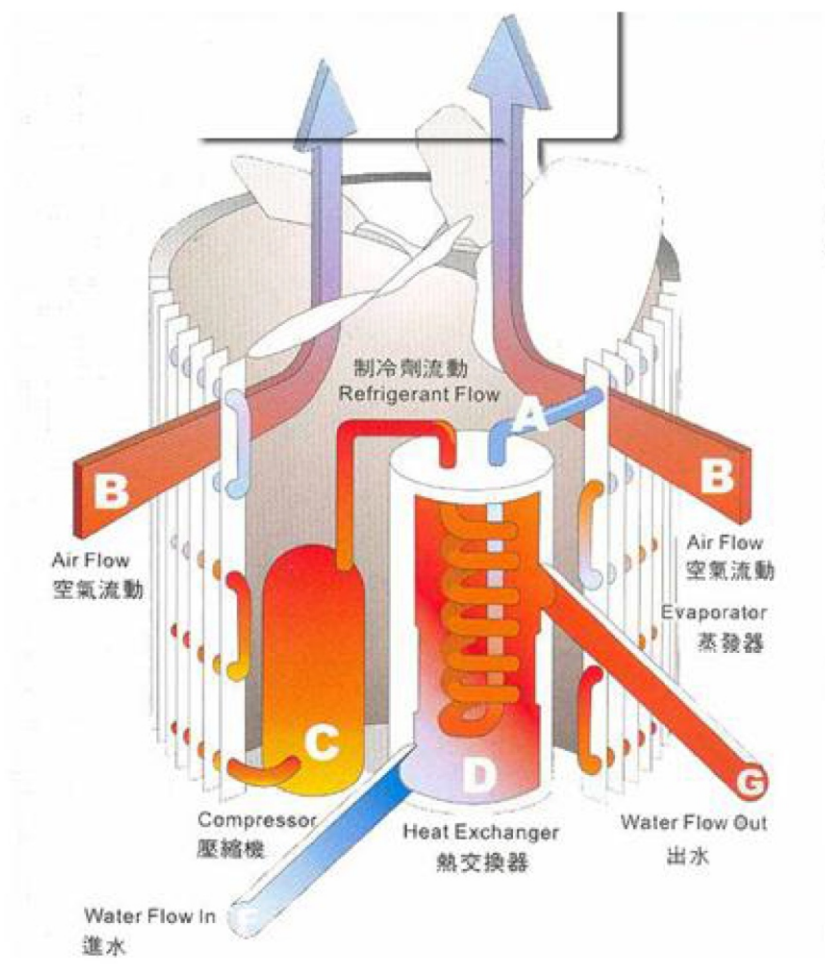



Solar Collector:ZP-SC-01



Seperated Solar Model:ZP-SP-01



Non-pressurized Model:ZP-SS-01



Non-pressurized Model:ZP-SS-02



Non-pressurized Model:ZP-SS-03



Pre-heated Model: ZP-PH-01



Plate Solar Model:ZP-PS-01



Plate Solar Model:ZP-PS-02



Air-source Model:ZP-AS-01



ALL-ROUND HOT WATER BUTLER



CE ISO9001-2000



Haining Kailide New Energy Co.,Ltd

Add: No. 18 Xincang Industry park, Haining,Zhejiang

TEL:0086-15868323666

E-mail: zhptyn@163.com